

PART NUMBER: 250-1732

TOOL SVC NUMBERS: 250-2598, 250-2600

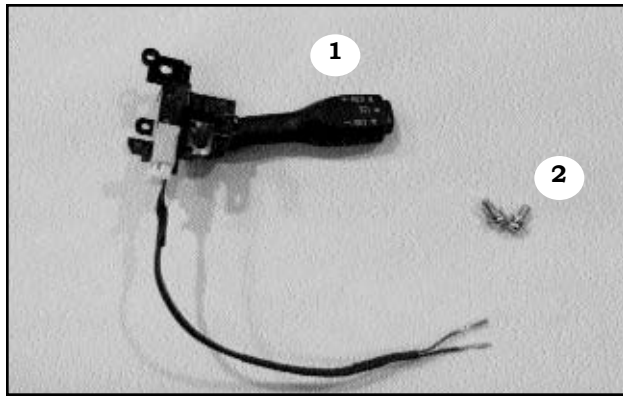

BASE KIT CONTENTS

ITEM	QTY	DESCRIPTION
1	1	CONTROL SWITCH ASSEMBLY
1	2	SCREWS (M5)

HARDWARE BAG CONTENTS

ITEM	QTY	DESCRIPTION

ADDITIONAL ITEMS REQUIRED FOR INSTALL

ITEM	QTY	DESCRIPTION
1	1	TOOL DIE/PART# 250-2598
2	1	EXTRACTION TOOL/PART# 250-2600

CONFLICTS

NOTE:

RECOMMENDED TOOLS

PERSONAL & VEHICLE PROTECTION	
SAFETY GLASSES	
FENDER COVER	
GLOVES (OPTIONAL)	
SPECIAL TOOLS	
BATTERY POST PROTECTOR	
INSTALLATION TOOLS	
TRIM REMOVAL TOOL	PHILLIPS SCREWDRIVER
10-MM WRENCH	T-30 BIT
SPECIAL CHEMICALS	

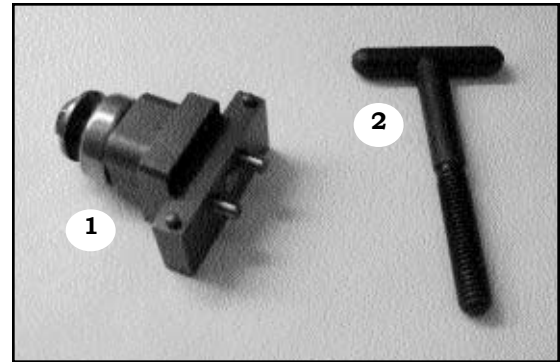

SVC CONTENTS

ITEM	QTY	DESCRIPTION	PART NUMBER
1	1	CUTTING TOOL	250-2598
2	1	EXTRACTION TOOL	250-2600

GENERAL APPLICABILITY

FJ CRUISER

SERVICE PARTS

ITEM	PART#	DESCRIPTION
1	250-2705	ECM CRUISE HARNESS

LEGEND

STOP: DAMAGE TO VEHICLE MAY OCCUR. DO NOT PROCEED UNTIL PROCESS COMPLIANCE HAS BEEN MET.

OPERATOR SAFETY: USE CAUTION TO AVOID RISK OF INJURY.

CRITICAL PROCESS: PROCEED WITH CAUTION TO ENSURE A QUALITY INSTALLATION. THESE POINTS WILL BE AUDITED ON A COMPLETED VEHICLE INSTALLATION.

GENERAL PROCESS: THIS HIGHLIGHTS SPECIFIC PROCESSES TO ENSURE A QUALITY INSTALLATION. THESE POINTS WILL BE AUDITED DURING THE ACCESSORY INSTALLATION.

TOOLS & EQUIPMENT: THIS CALLS OUT THE SPECIFIC TOOLS AND EQUIPMENT REQUIRED FOR THE PROCESS.

REVISION MARK: THIS MARK HIGHLIGHTS A CHANGE IN INSTALLATION WITH RESPECT TO PREVIOUS ISSUE.

SPECIAL NOTE: INSTALLATION SEQUENCES
 AFTER SAFETY MANDATED PREPARATORY STEPS HAVE BEEN TAKEN, THE INSTALLATION SEQUENCE IS THE SUGGESTED METHOD FOR COMPLETING THE ACCESSORY INSTALLATION. IN SOME INSTANCES THE SUGGESTED SEQUENCE IS WRITTEN FOR ONE ASSOCIATE TO INSTALL AND IN OTHERS THE SEQUENCE IS GIVEN AS PART OF A TEAM ACCESSORY INSTALLATION. UNLESS OTHERWISE STATED IN THE DOCUMENT, THE ASSOCIATES MAY PERFORM THE INSTALLATION STEPS IN ANY ORDER TO MAKE THE INSTALLATION AS EFFICIENT AS POSSIBLE WHILE MAINTAINING CONSISTENT QUALITY.

INSTALLATION

CONTROL SWITCH

LOCATION: RIGHT SIDE STEERING WHEEL COVER

**HARDWARE: REQUIRES CUTTING TOOLS 250-2598,
250-2600**



CAUTION: ENSURE THAT BATTERY HAS BEEN DISCONNECTED FOR MORE THAN 90 SECONDS PRIOR TO REMOVAL OF AIRBAG; FAILURE TO HEED THIS WARNING MAY RESULT IN AIRBAG DISCHARGE AND MAY CAUSE SERIOUS INJURY OR DEATH.



FIGURE 1



1. REMOVE AIRBAG BY RELEASING SIDE PANELS FROM STEERING WHEEL AND EXTRACTING THE TWO 30 TORX SCREWS AS ILLUSTRATED IN **FIGURE 2**.

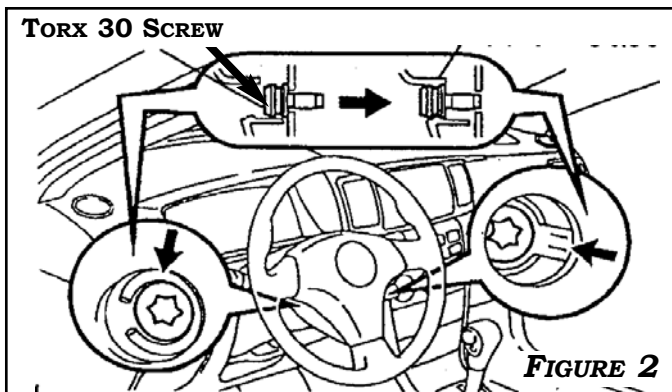

FIGURE 2

2. UTILIZE SMALL SCREWDRIVER TO REMOVE AIRBAG CONNECTORS AS ILLUSTRATED IN **FIGURE 3**.

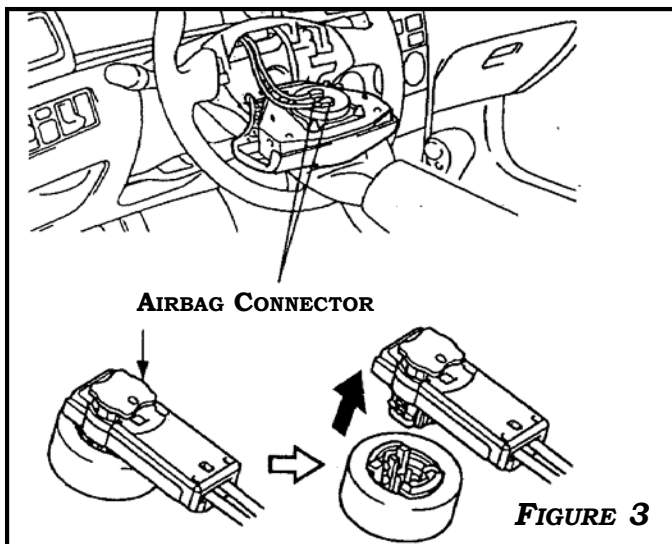

FIGURE 3



CAUTION: BE SURE TO STORE AIRBAG FACE UP AS ILLUSTRATED IN FIGURE 3 TO REDUCE INJURY IN EVENT OF ACCIDENTAL DISCHARGE OF AIRBAG.

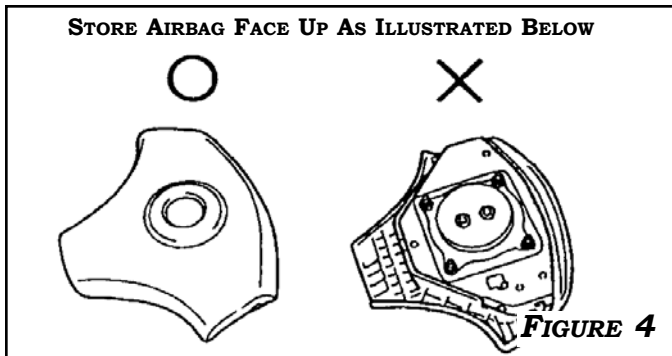

FIGURE 4

INSTALLATION

CONTROL SWITCH CONTINUED



3. USING THE **SWITCH HOLE CUTTING TEMPLATE** ON PAGE 5, PLACE THE TEMPLATE ON THE INSIDE OF THE TRIM PIECE AS SHOWN AND DRILL TWO (2) 5MM (13/64") HOLES AND ONE (1) 8MM (11/32") HOLE. **FIGURE 5**

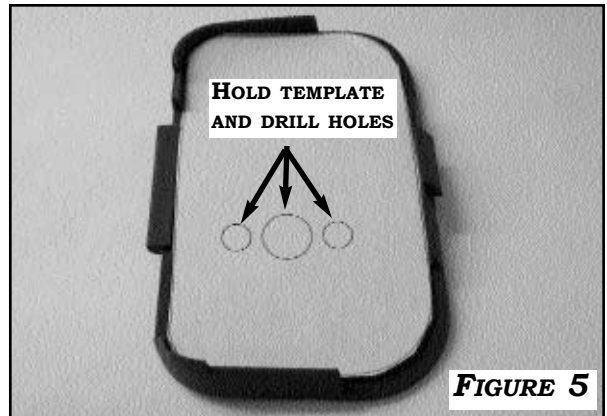

4. USING THE **SWITCH HOLE CUTTING TOOL, 250-2598**, INSERT THE CUTTING TOOL INTO THE DRILL HOLES OF TRIM PIECE AND WITH 13MM SOCKET, TIGHTEN THE SCREW UNTIL PLASTIC HOLE IS CUT OUT. **FIGURES 6 & 7.**

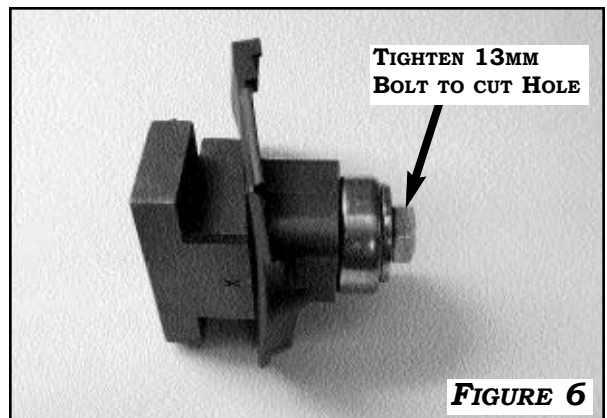

5. SOMETIMES THE CUTTING DIE MAY GET LODGED IN THE STEERING SHROUD MATERIAL; IN THIS CASE, UTILIZE THE CUTTING EXTRACTION TOOL, **250-2600**, TO REMOVE DIE.

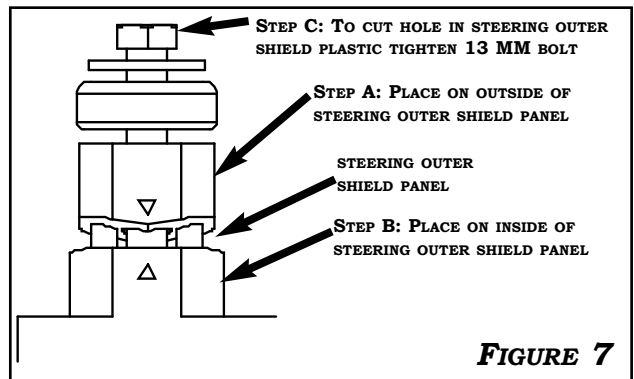

THREAD T-BOLT INTO DIE AS SHOWN IN **FIGURE 8** AND PULL TO REMOVE DIE FROM STEERING SHROUD.

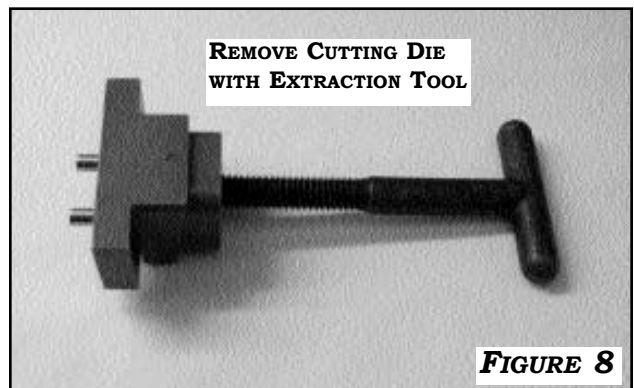

INSTALLATION

CONTROL SWITCH CONTINUED



6. MOUNT CRUISE CONTROL SWITCH WITH TWO (2) PHILLIPS SCREWS PROVIDED. LOCATE STEERING WHEEL CONNECTOR AS SHOWN IN **FIGURE 10**. UNPLUG CONNECTOR AND PULL UP LOCKING TAB SHOWN IN **FIGURE 11**. INSERT **RED WIRE** FROM SWITCH TO **PIN 5**. INSERT **BLACK WIRE** FROM SWITCH TO **PIN 4**. REASSEMBLE LOCKING TAB ON CONNECTOR TO SECURE PINS. RETURN CONNECTOR TO STEERING WHEEL.



7. REINSTALL AIRBAG.

8. REINSTALL TWO (2) STEERING WHEEL SHROUD TRIM PIECES.

REASSEMBLY

1. RECONNECT NEGATIVE BATTERY CABLE AND TORQUE TO **3 FT*LBS.**

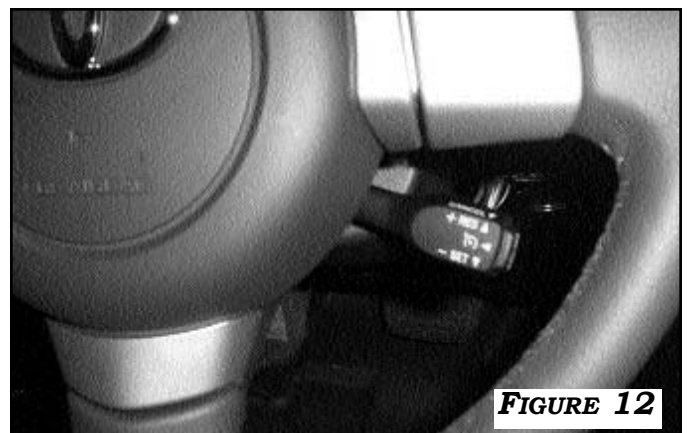
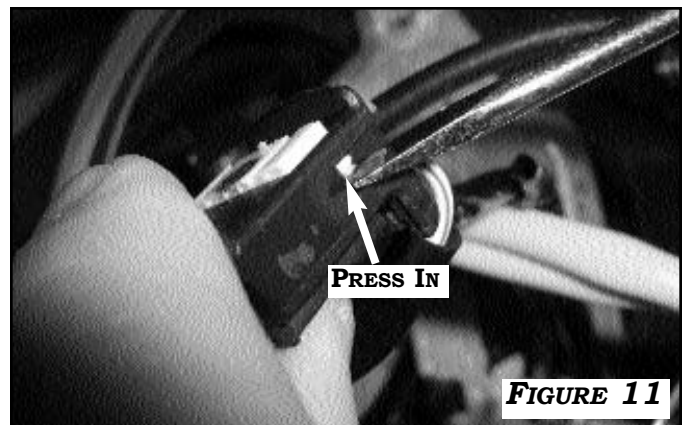
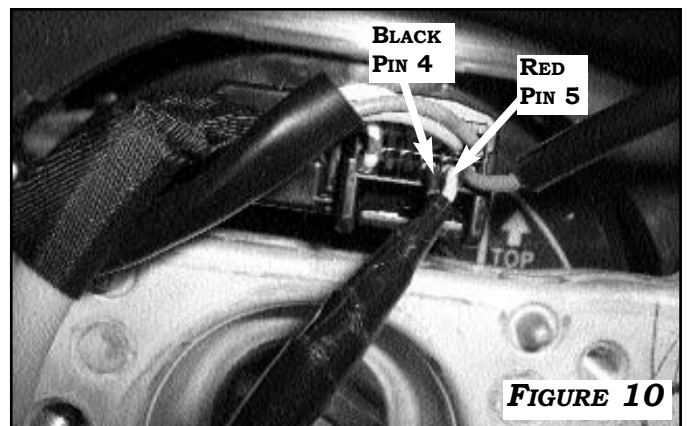
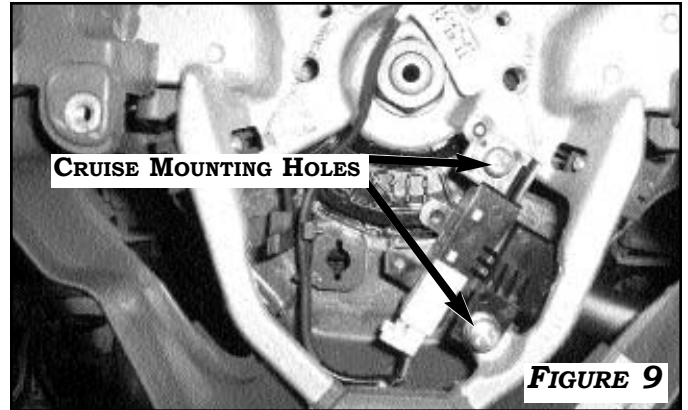

TROUBLESHOOTING

REQUIRES SERVICE HARNESS: 250-2705

NOTE: SOME FJ CRUISER VEHICLES MAY NOT BE PREWIRED FOR CRUISE.

1. REMOVE STEERING SHROUD. LOCATE BLACK CLOCKSRING CONNECTOR ON BACKSIDE OF STEERING WHEEL AS SHOWN IN **FIGURE 13**.
2. IF **PIN 5 BLUE/BLACK** WIRE IS VACANT, INSERT PIN FROM SERVICE PART HARNESS **250-2705** AND ROUTE TO ECM BEHIND GLOVE BOX. INSERT OTHER PIN ON HARNESS TO SECOND FROM BOTTOM CONNECTOR **E46 PIN 2** AS SHOWN IN **FIGURE 14**

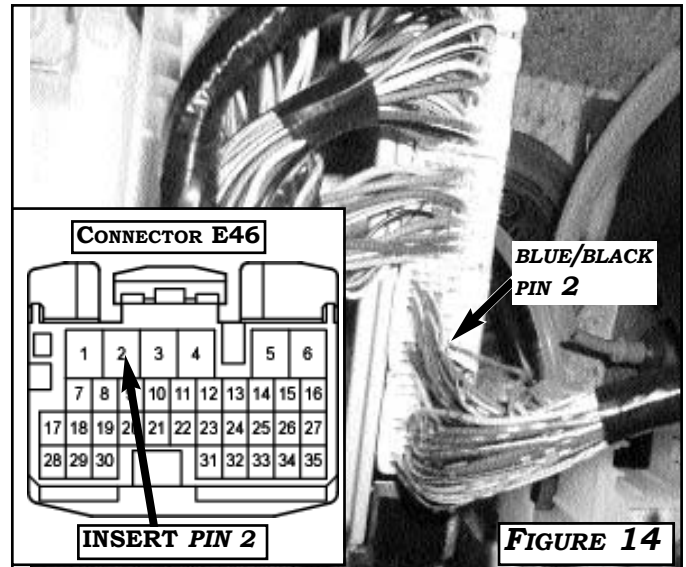
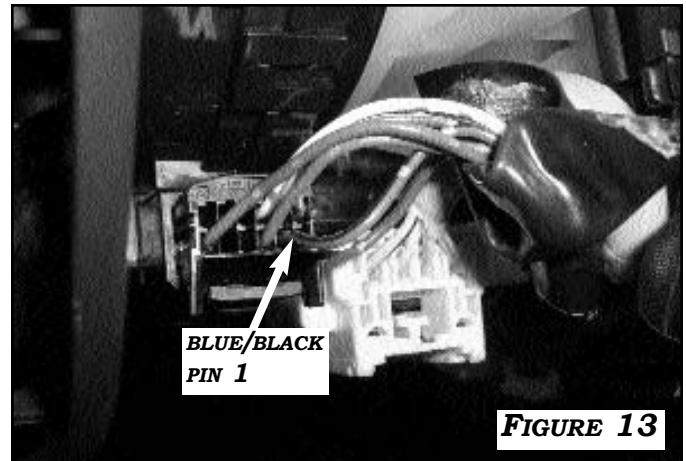

NOTES

TEMPLATE

